

Lead Compensator Design for DC Motor Driven Electromechanical Fin Actuator

Pavle Adamović¹⁾
 Zlatko Petronijević¹⁾
 Nebojša Jovičić¹⁾
 Aleksandar Stefanović¹⁾
 Miloš Pavić¹⁾

This paper presents modeling, simulations and control of the ground-to-air missile fin actuation system, where brushed DC motors are used as actuators, which are driven using voltage regulation-Pulse Width Modulation (PWM). The mathematical model of the system was determined using the differential equations of behavior of the lowest order that was experimentally confirmed. This model was taken as a starting point in the synthesis of the Lead compensator, used to regulate the position of the missile's control surfaces. The trial and error method was used for the synthesis of Lead compensator, taking care to meet the required characteristics of the System, in form of bandwidth and gain. The improved transient process and behavior of the System have also been experimentally confirmed

Key words: Fin actuation system, DC motor, Lead compensator, control surfaces.

Introduction

By developing different forms of regulators, it was tried to obtain better static and dynamic properties of the system for fin control, but with the development there was generally an increased complexity of the regulator, which led to the difficulty of implementing it into the system and synthesizing it. When it comes to fin actuators in the form of DC motors with brushes, simple regulator solutions in the form of PID regulators or compensators with phase lag or lead are still showing enviable properties. Such regulators are simple to synthesize and implement and in most cases are used in today's systems.

System description

Fig.1. shows a block diagram of the VRVZ-200 rocket control rudder driver with positional feedback, which has the task of moving the missile rudder in accordance with the input control signal. The initial signal corresponds to the required (desired) value of the rudder deflection angle. The signal from the positional feedback loop is subtracted from the input signal and represents the system error which is amplified and fed to the input of the phase lead compensator, which determines the required control of the DC motor. The motor torque is increased (angular velocity decreases) by means of a reducer, which is introduced into the servo system in the form of a reducer with a screw transmission and balls (spindle) and leads to fin - the rudder, under the influence of which the rudder rotates around its axis of rotation.

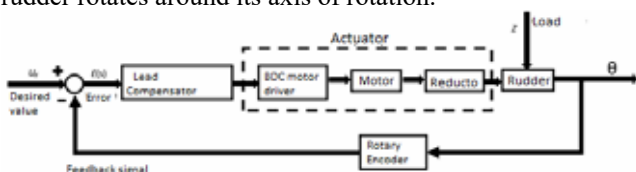

Fig.1. Block diagram of a rudder servo actuator

A direct current motor (DC motor) is often used to drive a fin actuator system.

Based on the equations that describe the behavior and dependence of certain quantities in the motor, the block diagram of the DC motor shown in Fig.2 can be drawn.

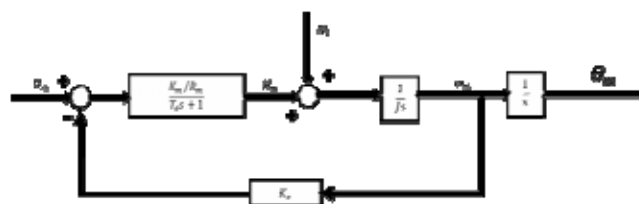

Fig.2. Block diagram of a DC motor

Where quantities are:

- U_m -stator power supply
- K_m - torque constant of the motor
- K_e - electrical constant of the motor
- R_m - motor winding resistance
- T_e -electrical time constant of the motor
- M_m -motor torque
- M_L - load torque
- θ_m - rotation angle of the rotor
- ω_m -angular velocity of the rotor
- J - moment of inertia

After the motor, there is a reducer with a ball-spindle screw transmission. The screw (spindle) transmission (bolt and nut, Fig.3.) transforms the fast rotational movement into a slower translational movement of the nut, which is transformed into the rotational movement of the rudder shaft by means of a lever mechanism. The bolt is attached to the motor shaft, and the nut to the rudder via the lever with slot and slide.

The advantage of this type of transmitter is the small overall dimensions of the system, simple construction and manufacturing. In order to reduce high friction and losses, a screw and a nut with balls were used.

The reducer with screw and nut with balls is used in actuators that require high positioning accuracy.

The efficiency coefficient of a reducer with a screw and a nut with balls can reach a value of 0.9. Frictional forces in the transmission are independent of speed. The gap can practically be completely eliminated.

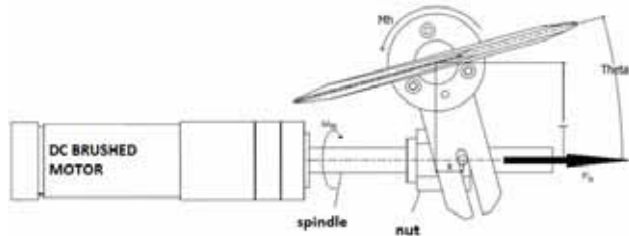

Fig.3. DC motor with screw gear

The transmission ratio of this reducer is obtained from the equation 1

$$i = \frac{2\pi l_{\delta}}{\cos \delta h} \quad (1)$$

Analysis and synthesis of the missile rudder electro-servo drive system

Fig.4 shows a linear block diagram of a servo system without a synchronizer.



Fig.4. Block diagram of an uncompensated linear system with no load

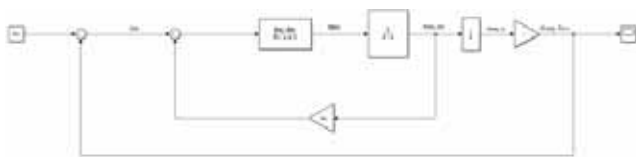

Fig.5. Block diagram of an uncompensated closed loop linear system with no load

After inserting the parameters of the reducer into eq.1, we get that the transmission ratio is the $i = 0.0074462$.

After entering the motor data taken from the catalog and the corresponding coefficients, the transfer function of the servo system of the given missile is obtained (equation (2)).

$$W_0 = \frac{42790637.6665126 * 0.0074462}{s^2 + 5088.96797153025 * s^2 + 1702585 \cdot s} \quad (2)$$

4. Synthesis of phase lead compensator

The transfer function 2 was taken as a starting point in the synthesis of the phase lead compensator. The condition is given that the damping of the system is $\xi = 0.6$ and that the bandwidth is $\omega = 50.2 \frac{\text{rad}}{\text{sec}}$.

It must be taken into account that the nominal voltage of the selected motor is 36V, but the system will be powered by a 24V battery.

The phase lead compensator itself works on the principle of increasing the gain of the system for higher frequencies, thereby increasing the phase between its zeros and poles.

The transfer function of the phase lead compensator is given in the form:

$$W_r = K \cdot \frac{s \cdot T1 + 1}{s \cdot T2 + 1} \quad (3)$$

where $T1 > T2$

Second form is:

$$W_r = K \cdot \frac{\frac{s}{\omega_z} + 1}{\frac{s}{\omega_p} + 1} \quad (4)$$

From which it follows that:

$$T1 = \frac{1}{\omega_z} \quad (5)$$

$$T2 = \frac{1}{\omega_p} \quad (6)$$

It is necessary to determine the coefficients $T1$ and $T2$, respectively the limiting frequencies ω_z and ω_p and the gain K so that the given criterion is satisfied. Determining the coefficients of phase lead or lag compensator is usually done by the Trial and Error method, but the number of possibilities is reduced by some additional condition during determination.

In this case, it was assumed that the ratio of coefficients $T1:T2=10$, which makes it easier to determine. The Matlab program was used as an helping tool.

After a certain number of attempts, the coefficients $T1=150$ and $T2=15$ were determined, but it is necessary to determine the gain K , since although we obtain a stable system according to the Bode criterion, which can be seen from Fig.6, the specified conditions are not met.

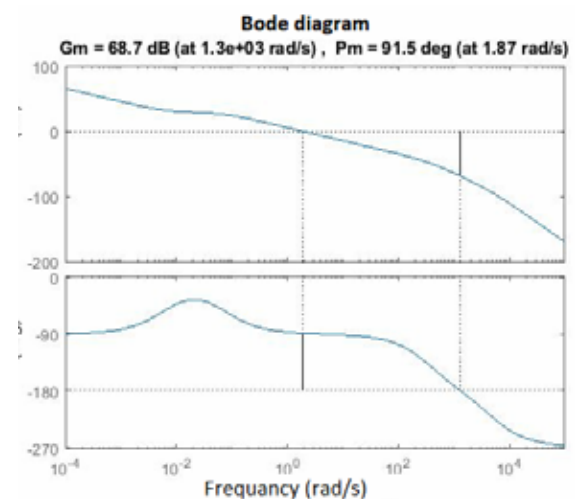

Fig.6. Bode diagram of system with phase lead compensator without gain

The gain K is determined by the R1 graph in the Fig.7.

From the condition that the damping is $\xi = 0.6$, the amplification $K=108$ is determined.(Fig.8) By checking the stability, we determine that the system with the given gain is stable, which can be seen in Fig.9.

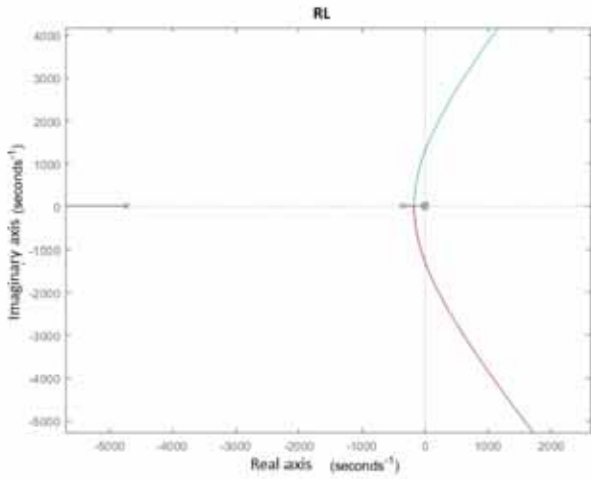

Fig.7. RL graph of a system with phase lead compensator without gain

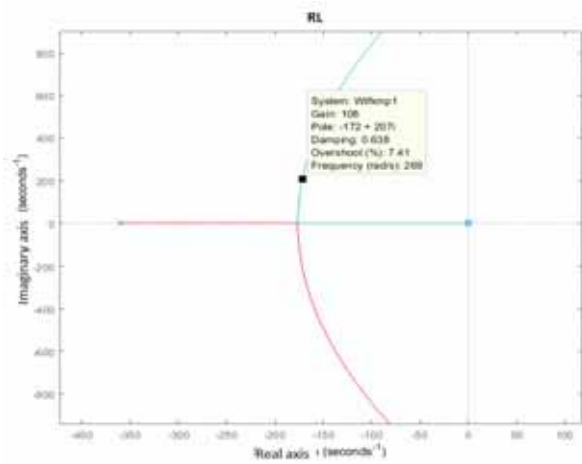

Fig.8. Adequate system gain with phase lead compensator

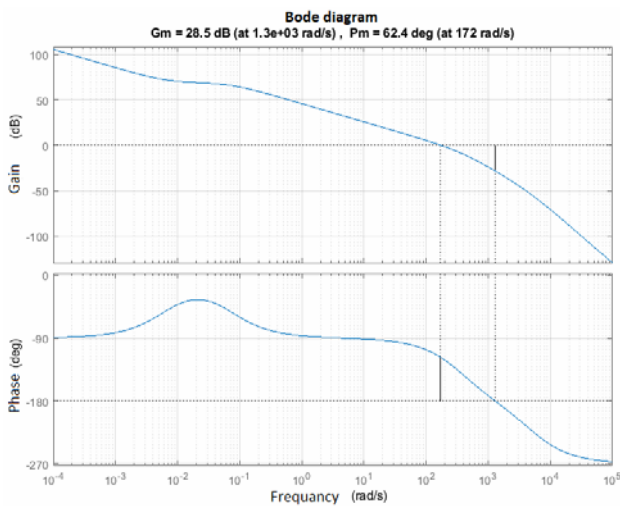

Fig.9. Bode diagram of a system with the adequate gain

On the Bode diagram of the closed circuit of the system with adequate coefficients, it can be seen that the bandwidth condition is also fulfilled. (Fig.10) For a given frequency of 8Hz, which is about 50 rad/s, the gain of the system is 0.0344 dB, which corresponds to a limiting gain of 3dB. The bandwidth of this system is 283 rad/s, which is about 45Hz, of course this is impossible in a real case, due to the existence of the maximum possible control of 24V, friction, gaps and other elements that were included during the synthesis.

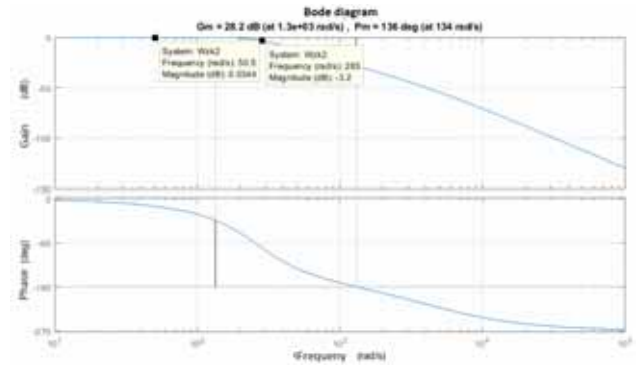

Fig.10. Bode diagram of a closed loop system with a adequate gain

Analysis of phase lead compensator

After the synthesis of the compensator, it is necessary to perform an analysis of its operation, that is, to see to what extent the compensator itself improves the properties of the entire system and how the system will behave with different input signals.

Matlab's Simulink tool was used to analyze the system. The block diagram of a continuous system with a phase lead compensator is shown in Fig.11.

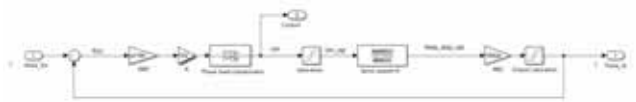

Fig.11. Block diagram of the system with phase lead compensator

In order to make the system simulation more realistic, output and control saturations were kept. The maximum angle at which the flaps can be turned is $\pm 20^\circ$, while the maximum voltage that can be supplied to the motor for maximum control is 24V DC.

The sine function, step function and quadrate function are supplied as system inputs.

Fig.12. shows the response of the system to the stepped function as a substitute for the step, since the middle position of the flaps is marked as 0° , so it is shown how the system behaves when the fins are rotated in both directions.

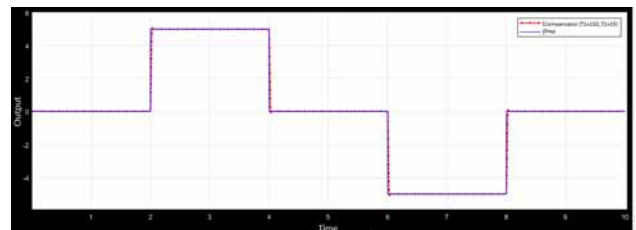

Fig.12. Continuous system output (step function)

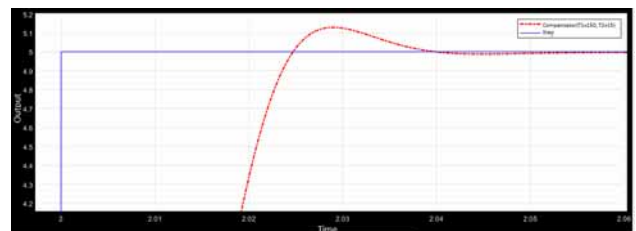

Fig.13. Output of continuous system (step function)-magnified

A better representation of the response can be seen in Fig.13, it can be said that the system follows the desired value well. The overshoot of the system is insignificant and

amounts to about 3%, and the rise time is $t_u = 0.025$ s, while the settling time is about $t_s = 0.05$ s, the stationary error is almost completely removed.

Next, the response of the system to a periodic input is shown in the form of a sine function, which can be seen in Fig.14.

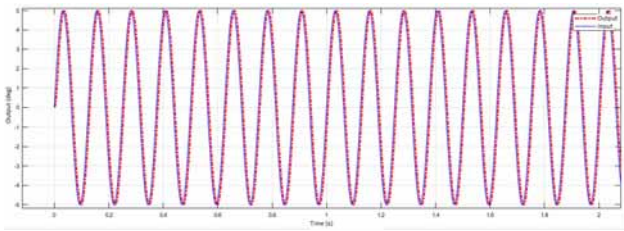

Fig.14. Continuous system output (sine function-8Hz)

In this case, the input signal frequency of 8Hz and amplitude of 5° is set, which corresponds to the initial requirements of the system characteristics. The output of the system closely follows the desired value, which corresponds to the indicators on the bode plot in Fig.10.

As shown, the system gain is close to zero, while the phase lag is about 10° .

The bandwidth for this type of system model, if saturations are included, is around 15Hz. (Fig.15.)

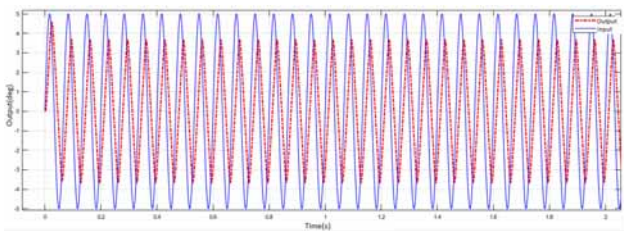

Fig.15. Continuous system output (sine function-15Hz)

The real system is not continuous, but discrete, so in order to perform the analysis of the system in full, it is necessary to first discretize the existing model of the continuous system and later to examine such a model.

Discretization was performed using the bilinear method or the Tustin method, and the sampling time is $T=1$ ms or $T=0.001$ s.

The bilinear method is performed:

$$s = \frac{2(z-1)}{T(z+1)} \rightarrow W_s \quad (7)$$

Each complex s from the continuous transfer function W , is changed with eq.7.

After the discretization, the transfer function of the phase lead compensator takes the form:

$$W_r = \frac{102(9.999700009999666 \cdot z - 9.999633345555148)}{z - 0.999922225555482} \quad (8)$$

After discretization, the transfer function of the object takes the form:

$$W_0 = \frac{(2.02664935e^{-5} \cdot z^2 + 3.391045e^{-5} \cdot z + 1.9056724e^{-6})}{(z^3 - 1.706487172 \cdot z^2 + 0.7126515508163z - 0.006164378419)} \quad (9)$$

Discretization was performed using Matlab, with the command `c2d()`.

Figures 16 and 17 show a comparison of the output of a continuous and discrete system for a step input signal.

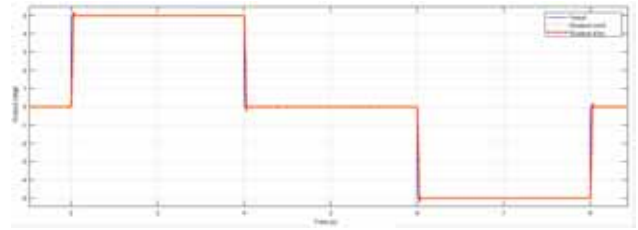

Fig.16. Comparison of response of discrete and continuous system to step input signal

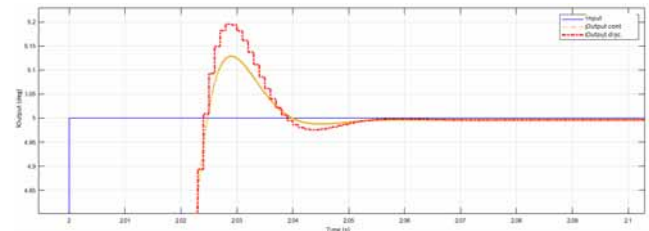

Fig.17. Comparison of response of discrete and continuous system to step input signal- magnified

It is noted that the deviations of the output of the discrete system from the continuous one are negligibly small, which means that the discretization was performed correctly, and the behavior of the real system should not have any major deviations from the behavior of the simulated system model.

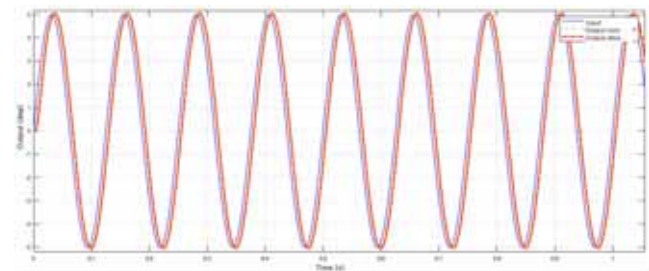

Fig.18. Comparison of the response of a discrete and continuous system to a sine input signal

With periodic inputs, it is also observed that the outputs of the discrete and continuous model of the system match, which additionally confirms the quality of the modeled system. (Fig.18.)

With the real system, the problem is that it was not possible to achieve continuous control, instead pulse width modulation (PWM) of the controller's output signal was performed. An analysis of such a system was performed, and the matching of it and the pure continuous modeled system was verified.

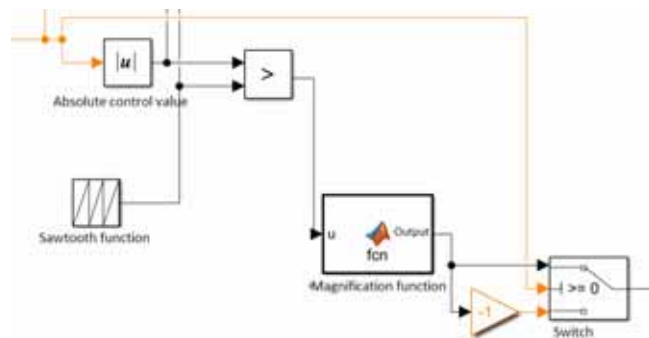

Fig.19. Block diagram of the PWM block in Simulink

The operation of the PWM block is based on the principle of comparing the absolute value of the continuous control and the sawtooth function has a peak at 1, if the control is greater than the current value of the sawtooth function, a 1 is sent from the comparator and vice versa, then in the magnification

function if it is received as an input 1 at the output it sends 24 or if 0 is obtained, 0 is sent and finally, depending on the sign of continuous control, the function is exited with + or - and such a signal is further sent to the object. (Fig.19.)

It can be seen in Fig.20. that the outputs of the continuous system and the system with PWM almost overlap, except in the stationary state where the output of the system with PWM has small oscillations, but within the allowed limits (Fig.21).

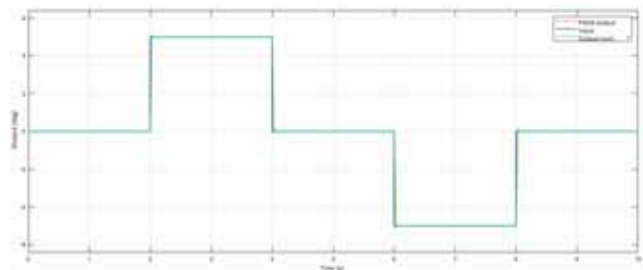

Fig.20. Comparison of the response of a PWM system and a continuous system to a step input signal

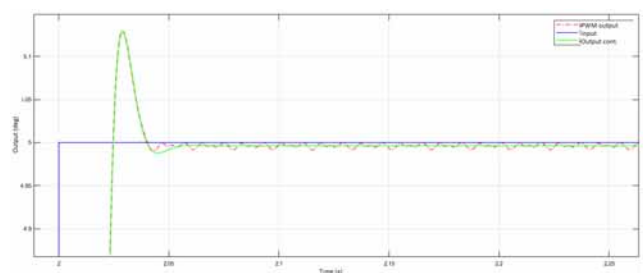

Fig.21. Comparison of the response of a PWM system and a continuous system to a step input signal- magnified

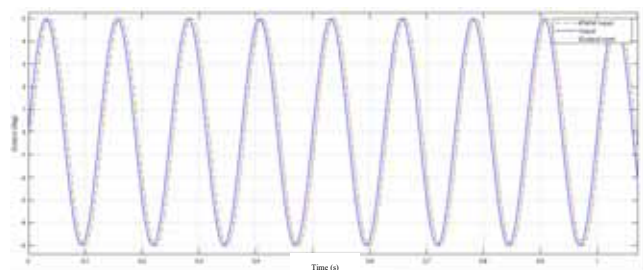

Fig.22. Comparison of the response of a system with PWM and a continuous system to a sinusoidal input signal

For testing of the real system, a special construction is made. The DC motor together with the spindle and the reducer and the handle for the fins is inside a steel tube.



Fig.23. Resistance simulation mechanism

Instead of the flaps, a mechanism with a lever is attached to the supports, which is attached to the table through the ends, by means of a spring. This mechanism should simulate the moment that occurs when turning the wing and which tries to return the flap to the zero position (resistance moment) (Fig.23)

Fig.24 shows the response of the real system to the step input signal. It must be taken into account that the signal received from the sensor contains a lot of noise, as can be seen in the picture, and that the phase lead compensator has a very large differential effect and reacts quite aggressively to fast changes in the error, so the system will never remove the error completely. The static error is about 0.1° , which is not bad, if you take into account the characteristics of the system, while the overshoot is about 0.5° , or 8%.

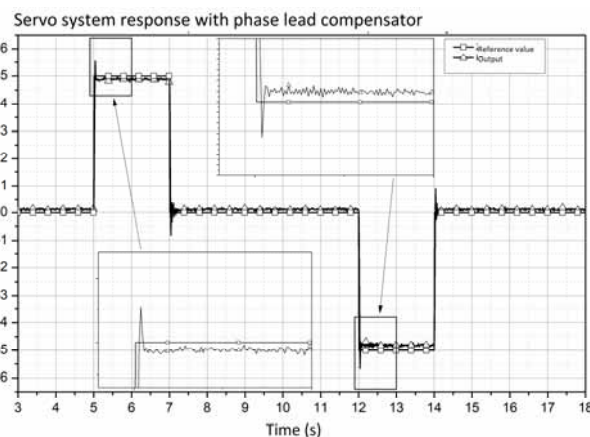

Fig.24. Response of a real system to a step input signal

Conclusion

With a good knowledge of the system's characteristics, that is, if the transfer function of the system is correctly determined, it is possible to simply synthesize a compensator with valid characteristics, which is easy to implement, which shows why it is still used today in the control of certain systems. The synthesis of the phase lead regulator was carried out, which managed to provide satisfactory dynamic characteristics.

References

- [1] RISTANOVIĆ, M., LAZIĆ, D., ČOJBAŠIĆ, Ž.: *Intelligent control of DC motor driven electromechanical fin actuator*. Control Engineering Practice, June 2012.
- [2] TENNAKOON, W., MUNASINGHE, S.: *Design and Simulation of a UAV Controller System with High Maneuverability*, December 2008.
- [3] SHEIBANIA, A., POURMINA, M.A.: *Simulation and Analysis of the Stability of a PID Controller for Operation of Unmanned Aerial Vehicles*. Springer, Berlin, Heidelberg, 2012.
- [4] SHAO, P., ZHOU, Z., MA, S., BIN, L.: *Structural Robust Gain-Scheduled PID Control and Application on a Morphing Wing UAV*, Dalian, China, 26-28 July 2017.

Received: 22.07.2022.

Accepted: 12.09.2022.

Sinteza regulatora sa faznim prednjačenjem za servo sistem pokretača upravljačkih površina

Ovaj rad prikazuje modeliranje, simulaciju rada i upravljanje sistemom za pokretanje upravljačkih krilaca rakete zemlja-vazduh, gde se kao aktuatori koriste motori jednosmerne struje sa četkicama, koji se pokreću pomoću regulacije napona- Širinsko impulsna modulacija (ŠIM). Matematički model sistema je određen korišćenjem diferencijalnih jednačina ponašanja najnižeg reda, što je eksperimentalno potvrđeno. Ovaj model je uzet kao polazna tačka u sintezi Kompenzatora sa faznim prednjačenjem, koji se koristi za regulisanje položaja kontrolnih površina rakete. Za sintezu Kompenzatora sa faznim prednjačenjem korišćena je metoda pokušaja i grešaka, vodeći računa da se ispune zahtevane karakteristike sistema, u vidu propusnog opsega i pojačanja. Poboľšani prelazni proces i ponašanje sistema su takođe eksperimentalno potvrđeni.

Ključne reči: Sistem za pokretanje upravljačkih krilaca, Motor jednosmerne struje, Kompenzator sa faznim prednjačenjem, upravljačke površine.