

Hybrid Drivetrain Design – Working Principle and Application

Sanja Vasin Bojic¹⁾

Emerging engineering challenges in wind power electricity generation bond with stringent industrial requirements, have tendency to outline development and design process in the ready set go manner. From given predisposition one of the consequences may be highlighting of certain research area or even worse - deflection from the basic functional requirements in wind turbine drive train design. The paper presents a proposal of novel drive train technology – gear transmission unit with continual variation of transmission ratio which can provide direct synchronization to public electric grid, efficient energy conversion and wider operating range of wind turbine rotor. Beside mechanical, electronic and software system design, novel wind turbine configuration is also presented.

Key words: design, drivetrain, continual variation, wind turbine, hybrid system.

Introduction

A MOUNT of captured wind energy is rapidly increasing through wind turbine (WT) consecutive development, therefore making wind power industry a competitor in electricity generation market race. In whatever form of energy wind power should be transformed to, its unpredictable nature - sudden changes of speed velocity and direction must be taken into account [1]. Many researches based on modern Wind energy conversion systems (WECS) [2] have been conducted to achieve comprehensive fulfillment of stringent industrial requirements whose further extent is becoming more demanding. In contribution to that, wind energy policy defines a list of requirements that should be satisfied for optimal power exploitation: generated energy cost decrease, wind energy conversion efficiency increase, reduction of initial and maintenance system costs, higher system reliability and longer lifespan, grid codes compliance and grid integration, higher energy yield and power density, bigger system capacity and lower weight, WT power rating boost and lower power losses, reactive power compensation, lower space requirement and excess wind power storage, fast and reliable control system, reduced mechanical stress and harmonic oscillations, fault-ride through management, etc. It can be noticed that among these requirements there are many contradictions with high impact on overall system operation stability and efficiency concealed. Ability to solve these contradictions lays in synergy between mechanical, electro-electronic and software systems design and system parameters harmonization. Different generator and power converter topologies have been studied and some of them have been applied in practise [3], moving from WT with fixed-speed generators through semi/full-speed variable system. In search for the best option, development process of mechatronical system such as WT drivetrain has been redirected on working principle and design of electrical generators and power converters [4]. High-end electrical generator permanent magnet synchronous generator (PMSG) or even heat-temperature superconducting (HTS) generator, with all built-

in advantages supports gearless drivetrain in order of overall weight reduction, higher conversion efficiency, initial and maintenance cost reduction, etc. Still, none of these configurations fit the best solution – simple but thorough. An innovative breakthrough which results in broader WT operating range, direct synchronization to public electric grid and efficient energy transformation is presented in this paper [5].

State of the art

WECS system topology overview

Based on ability to adapt to wind speed and power changes, few WT drive train configurations originated in the following order: fixed-speed, semi-variable speed and full-variable speed WT. Further division is made on combining drive trains with electrical power converters to enable variable speed operation, eliminate soft starter and reactive power compensation. Main concern with power converters lays on their controllability, modularity (component count), efficiency of switching devices and their optimal arrangement, with presence of cooling system. By failure rate electrical power converters are at the top of the WT failure lists. Table 1 shows the properties of WT configurations according to a type of applied electric generator. Evaluation criteria are same for each configuration from economical ones – total and maintenance cost to technical ones – speed control, reliability, total efficiency and so on. It can be noticed that configurations with simpler structure are more reliable during system operation, lighter and cheaper. Configurations with electronic power converters and accompanying systems have higher efficiency, ability of speed and voltage control, high energy yield while their reliability depends on the component choice and arrangement. Beside presented ones, there are many alternative configurations derived with goal to eliminate existing system deficiency. However, each configuration brings new engineering challenges that should be solved in pursuit for unique yet practical and economical solution for wind power electricity production.

¹⁾ Military Technical Institute (VTI), Ratka Resanovića 1, 11132 Belgrade, SERBIA
Correspondence to: Sanja Vasin Bojic; e-mail: vasinsanja@gmail.com

Table 1. Evaluation criteria for WT configurations based on applied electric generator

WT Configuration type	SCIG	SCIG	WRIG	DFIG	WRSG	PMSG /EESG	HTS /Reluctant	Windspen
Speed control	Fixed speed (±1%)	Variable	Variable (±10%)	Variable (±30%)	Variable (±10%)	Variable (±100%)	Variable (±100%)	Variable (±100%)
Total cost	Lowest	High	Low	Medium	Medium	High	High	Medium
Weight	Minimal	Medium	Small	Medium	Medium	Small	Smallest	Medium
Reliability	High	Medium	Medium	High	High	High	High	High
Total efficiency	Low	Medium	Low	High	High	Very high	Very high	To be estimated
Design	Simple	Simple	Simple	Robust	Complex	Modular	Complex	Hybrid
Controllability	Poor	Good	Good	Very good	Very good	Very good	Very good	Predictive
Fault-ride through	None	Slip control	Slip control	Control system	Control system	Control system	Control system	Control strategy
Re/active power control	None	Dependent	Dependent	Separate	Independent	Independent	Independent	In flow prediction
Grid integration	Direct	Partially	Direct	Partially	Isolated	Isolated	Isolated	Direct
Voltage control	None	Weak	Weak	Good	Good	Good	Good	In flow prediction
Maintenance	Gearbox	Gearbox, converter	Gearbox	Gearbox, converter	Converter	Generator	Generator	Gearbox
Energy yield	Lowest	Low	Low	Medium	High	Very high	Very high	To be estimated
Grid sensitivity	Harmonics	Torque pulsation	Harmonics	Harmonics	Harmonics	Harmonics	Harmonics	Minimal sensitivity
Noise	High	High	High	Medium	High	Low	Low	Damped
Heating	High	High	High	Medium	Medium	Low	Low	Low
Mechanical braking	Required	Required	Required	Required	Required	Required	Required	No braking
Suitability	Home	Small to medium WT	Small WT	Medium WT	Small to medium WT	Small WT	Small WT	Universal

Drivetrain configurations have been developed from very simple to highly complex systems, in order to provide an efficient yet robust drive. From that matter, in the following WT configurations a trend is explained with a final view of novel configuration possibilities.

Type 1 (Fig.1), fixed-speed Squirrel cage induction generator (SCIG) without frequency conversion. Advantages – simple design, low initial costs, high reliability, reduced reactive power burden. Disadvantages - prone to grid faults, mechanical components stress, overheating, high noise, low efficiency, direct connection to grid.

Type 2 (Figures 2 and 3), semi-variable speed Wound-rotor induction generator (WRIG) with limited conversion of 10% or Doubly-fed induction generator (DFIG), with limited conversion of 30%. Advantages – high power systems, no overheating with higher efficiency and reliability. Disadvantages – rotor slip rings power losses, grid fault sensitivity, higher costs, and required soft starter.

Type 3 (Figures 4 and 5), fully-variable speed Permanent magnet synchronous generator (PMSG) or Wound-rotor synchronous generator (WRSG) with conversion rate of 100%. Advantages – good controllability, lower mass, direct drive, low losses, no external excitation current, independent control of active/reactive power, grid isolation. Disadvantages – higher maintenance costs, mechanical braking needed, generator size increase, demagnetization of permanent magnet.

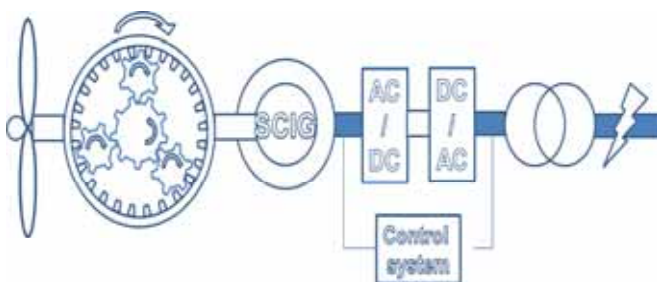

Figure 1. WT drivetrain Type 1 with SCIG

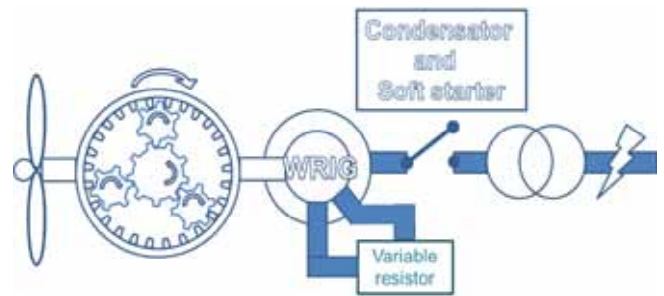

Figure 2. WT drivetrain Type 2 with WRIG

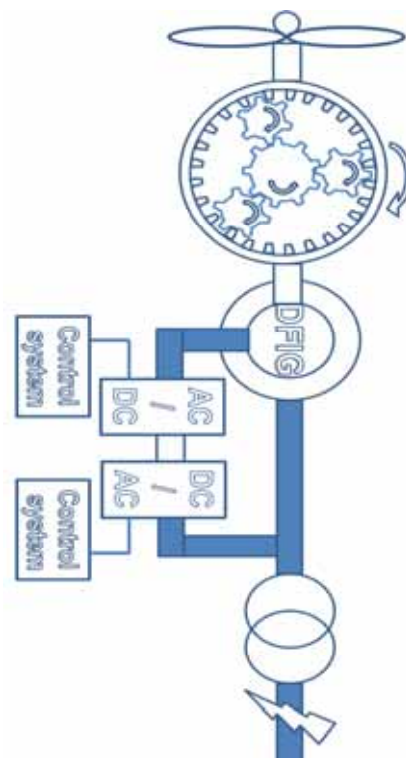

Figure 3. WT drivetrain Type 2 with DFIG

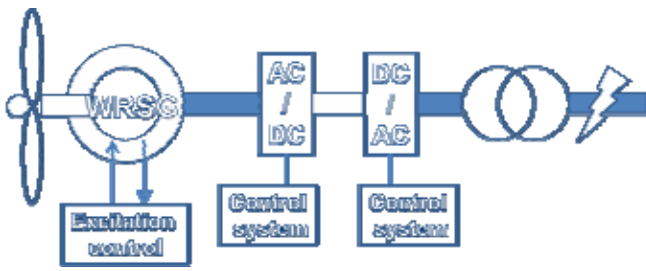

Figure 4. WT drivetrain Type 3 with WRSG

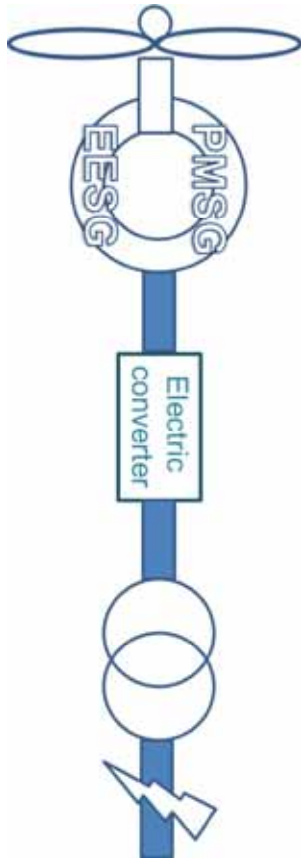

Figure 5. WT drivetrain Type 3 with PMSG or Electrically excited synchronous generator (EMSG)

Novel drivetrain technology

Simple yet practical solution may be new hybrid drive train with continual variation of power transmission ratio, whose working principle is given in Fig.6. Gear unit consists of one specific planetary gearbox $i=1/25$ without sun gear improving overall system reliability and another planetary gear set connected to generator. Depending on input the wind speed gear unit continually varies transmission ratio providing constant output generator speed which generates constant frequency to feed public electric grid. When wind is low the control system sends command to motor-generator which accelerates its speed of rotation. Being in mesh with ring gear, this acceleration transfers to gear planets and sun gear connected to generators high speed shaft. When wind speed is high, the motor-generator is slowing down. Thus the sun gear will also slow down providing constant output speed of gearbox and in same time constant input speed for electric generator. Due to constant generator speed the WT drive train is directly synchronized to public electric grid with frequency of 50/60Hz. The generator rated power is $P_G = 1,5$ MW and rotation speed $n_G = 1500$ rpm, respectively.

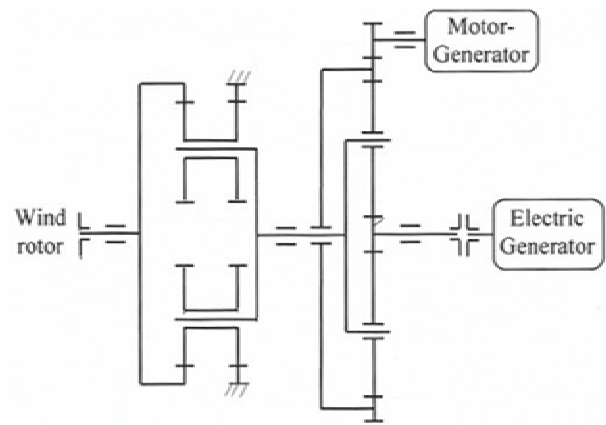

Figure 6. Working principle of hybrid drivetrain with continual variation of transmission ratio

Mechanical system design

In this paper a presentation of novel drivetrain on functional and embodiment design level is given. 3D model of mechanical gear unit of WT drive train is given in Fig.7. Embodiment design of housing and planetary gear carriers is optionally a welded structure. Gearbox is connected to rotor shaft with elastic coupling. The input shaft of gearbox is supported with cylindrical roller bearing. Another cylindrical roller bearing is positioned inside right end of gearbox shaft, to support planet carrier. Main planetary gearbox contains two inside toothed ring gears, where one ring gear is input (drive) gear and the other one is fixed – no rotation. Sun gear is eliminated for higher system reliability and longer operating life. Ring gears (input and output) are in mesh, each with one set of five planet gears, giving the total transmission ratio, $i=1/25$. A pair of spherical roller bearings is placed inside each of five-planet gear complete. Input ring gear is connected to main shaft of gearbox with rotation speed 10-18 rpm, by means of ring gear carrier. Presented concept of gear unit design provides significant mass and dimension reduction with increase of system reliability. Both planetary gear sets are connected by spline joint and supported with pair of cylindrical roller bearings. Thus total transmission ratio is variable according to the change of wind speed. The ring of planetary gear set for transmission ratio variation is toothed on both sides and rotates around bearing support. Internal teeth system is in mesh with the three planet gears supported with planet carrier directly connected to the main gearbox ($i = 1/25$). In the center of gear set is sun (output) gear placed at the end of the output shaft, which is connected to electric generator with elastic coupling. Outside teeth system of the ring is in mesh with additional gear connected to the motor-generator with reverse rotation, which provides variation of transmission ratio according to the wind speed in order to supply constant speed of the output shaft. The ring gear is connected to a carrier supported on cylindrical roller bearings placed in the central wall of the housing.

Total transmission ratio is $i=1/(83...150)$ which provides constant generator speed of 1500 rpm for wind rotor speed variation 18...10 rpm. Input speed of gearbox is equal to operating wind rotor speed of 12 rpm, output speed 1500 rpm, and input torque 1200kNm. These data correspond to transmission of 1.5 MW mechanical powers in the course of all operating life. When the wind speed is low, gear speed-up the planetary gear set, and when the wind speed is high, the gear slows down the ring, providing variation of this planetary gear set in the range of $i=1/(3,3...6)$. Due to the wind and rotor speed vary, transmitted power also varies in relation 0.4...2.5 MW.

Design parameters are selected using robust design methodology, which includes possible stochastic operation conditions, and stochastic failure probability of gear teeth flanks. Material selection together with gear teeth thermal treatment is chosen with the objective to obtain maximal load capacity with minimum of gearbox dimension. Desired gear drive reliability and service life duration of gear drive unit were the main constraints in design parameters definition.

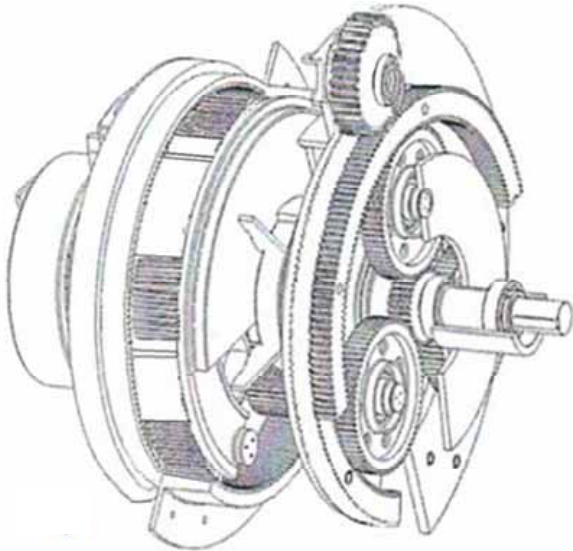

Figure 7. 3D model of hybrid drivetrain

Control system design

Main role in providing permanently constant speed 1500 rpm respectively, of output shaft and 3-phase AC generator, is in permanent variation of transmission ratio, Fig.8. This function is carried out by a gear connected to the gear ring. The gear is driven by PM-SM servo motor-generator. Electric current produced by 3-phase generator is under power monitoring system (PM). The power level, frequency and other characteristics are permanently monitored. Produced power after voltage transformation is transferred into public electric net (PEN). Digital signal processor (DSP) processes information about frequency variation and sends signals for pulse width modulation (PWM) and control of motor-generator. Motor-generator, alternatively changes direction and speed of rotation to consume and produce electricity. The speeds of rotation are relatively small and very often equal to zero (standing position). These are very strong operating conditions for motor-generator which has to be equipped by additional electronic system for protection. In addition, control and reaction of motor-generator control system has to be instant and permanent in order to keep the current frequency in the process of random and/or sudden variation of the wind – gust. Software for wind turbine control (SWTC) adapts DSP and PWM functional characteristics. This process is in interaction with power monitoring operators or it can be performed automatically by corresponding algorithmic procedure. To keep the constant generator speed of rotation 1500 rpm, when the wind speed is high, i.e. wind rotor speed 18 rpm and for output power 2.5 MW, motor-generator rotates in one direction providing the total transmission ratio $i=1/83$. For these conditions, the ring has to rotate with 500 rpm and motor-generator with 3000 rpm. In this condition, the motor-generator is acting as an electricity generator and brakes (inhibits) ring and produces maximal power of 0.6 MW. This is extreme condition when a strong wind appears. When the wind

speed is low, wind rotor rotates with 10 rpm, and motor-generator has to accelerate ring by power consumption. For this condition output power of WT is 0.4MW, motor-generator rotates providing the total transmission ratio, $i = 1/150$ at speed of motor-generator 420 rpm with maximal power consumption of 0.1 MW. Further research will be concentrated on development of testing methodology of mechanical, electronic and software system with implementation and feasibility study.

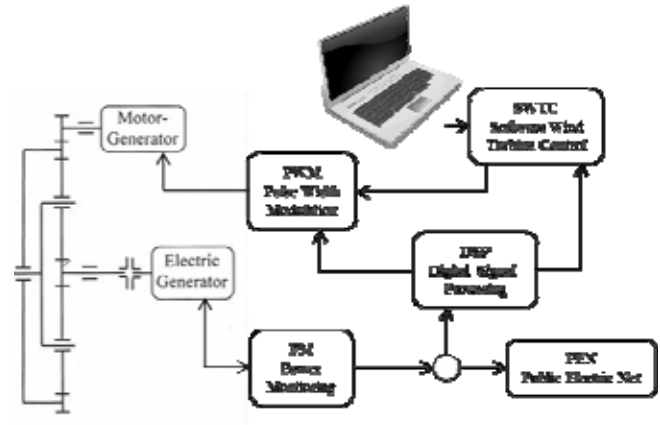

Figure 8. Design concept of control system

Software system design

Main goal is to provide a predictive decision making process in the system design, operation and field testing. In cooperation with control system, software system should provide constant overall system supervision with ability to predict future activities – actions based on past and present operating state conditions. This can provide maximal system efficiency. Input to software is predefined variables that are captured and processed by application of mathematical models of mechanical, electro-electronic and control systems. Concern is not only on outer variables such as – wind speed and direction. Real-time system properties should be included in integration of functions, behavior and optimized structure design. Models are yet to be presented on corresponding levels of complexity as abstract, physical, virtual, etc. Well defined models can present a basis for optimal system design – integrated model of whole drive train design with continual update of real-time properties.

Expected contributions

A proposal of new WT drivetrain configuration is given in Fig.9. In order to provide true aspect of novel drive train design contributions to wind power electricity generation, same evaluation criteria for electrical generators and electrical power converters have been adopted for novel solution:

- Efficient wind energy transformation – novel drivetrain technology has the ability for continuous variation of transmission ratio, which enables adaptive and real-time system respond to wind power and speed changes. Control and software system are yet to be developed as a full support to this action;
- Direct synchronization to electrical grid – novel gear unit eliminates power, voltage and grid fluctuations allowing direct connection to power grid;
- Wider operating range of WT rotor – operating from 0,5m/s (light breeze) up to 37,2m/s (stormy winds) given solution can capture more wind power instantly replacing several WT's with limited operating range;
- Efficient control system – based on predictive evaluation

- and implementation of past and present system states, it is possible to predict future system actions in course of smoother operating condition, prevention of possible brakes and/or failures. Well defined models of major system components play crucial role in control system reliability and are responsive;
- Robust and compatible design – design of mechanical system, control and software system should be defined by harmonizing system parameters for gain of expected system behavior. System should be insensitive to mechanical disturbances (resonance, vibrations) by appropriate damping system. Software validation and verification should be performed, to prevent bugging and other possible faults. Control system threshold and control function must be carefully defined to avoid the system delay, overheating and so;
 - Higher system reliability – needed number of system components and their parameters should be chosen in order to provide an efficient system planning and development. With application of proposed design, it is possible to configure simpler but more reliable design of the WT drivetrain. Complex electric converters and generators could be replaced with simpler but more reliable substitute. Since there is no need for elimination of mechanical and electrical fluctuations some of the components can even be removed from typical system design, i.e. electrical power converters.
 - No system braking – providing continuous variation of transmission ratio momentarily to change of wind speed and power, novel drivetrain design eliminates need for overall system braking. Whether there is mild or strong wind blowing, the system can operate without stoppage and/or response delay.
 - Lower WT drive train weight – embodiment design of new 3-stage planetary gearbox is defined as optimal relation between the system structure, behavior and function. Lightweight design with required strength and simplicity of drivetrain structure should provide extreme weight reduction;
 - Predictive decision making control system - numerical and experimental methods should be integrated into control system database for stress and operating conditions estimation, weak points estimation, monitoring of component lifespan based on calculated reliability, predictions and estimation of past, present and future states during system operation and/or testing;
 - New development and testing methodology for developed drivetrain model present foundation for development of other mechatronic systems, with implementation in any scientific research area;
 - Developed solution advantages are – ability of direct synchronization to electric public grid, constant output frequency/input speed of electric generator, wider rotor operating range, maximal compatibility and robustness of given solution, system control in variety of working conditions and real-time constraints;
 - Frequency transformation of electric current using special transformers with significant losses in the new solution is eliminated. Speed of turbine rotor and wind speed cannot be limited in this solution operation. The brakes in the new solution are replaced by motor-generator. Instead of breaking, the motor-generator produces electricity.
 - Methodology for hybrid drivetrain development – design of mechanical, electronic, software system and testing ring design, yet needs to be defined on the finest levels of the system parameters integration. This implies that each component with well-defined function can be described as an abstract or mathematical model. Next step in integration process is to define real system properties as physical model. From this level it is possible to define virtual model which functions, behavior and properties than can be changed, redefined or even substituted during design process. Therefore, beside vertical integration of the process steps, horizontal integration must also be included. In further work the embodiment design of novel WT drivetrain as well as conceptual design of electro-electronic and software system design will be defined through an integrated design process with implementation of modular and evolutionary engineering approach. Modular approach should provide full synchronization off all the research areas on micro and macro level. Macro level leads to continuous information exchange within multiple expert teams on well-defined development level. From micro level, analysis and prediction of functions, effects and system properties in product development should be hierarchically defined with an estimation of possible results and expected behaviour. Simultaneous development of mechanical, electronic, software and control system should result in fundamental development and design methodology for hybrid technical systems of different purpose.

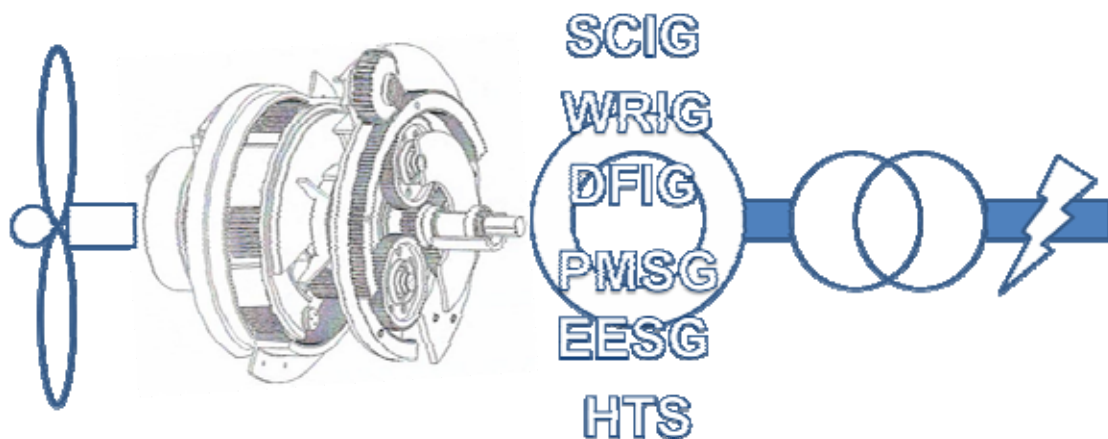

Figure 9. WT drivetrain configuration with novel technology

Conclusion

Besides in the wind power electricity generation, hybrid drive train can also be applied in any field of research where there is a need for transformation of variable input speed into constant output speed – automotive industry, military battle field vehicles and so on. Variable ratio transmission unit can be connected to any of the electric generators applied in wind power electricity generation. New gearbox coupled with electric generator may have the ability to give optimal results concerning overall system efficiency, energy yield, and constant frequency production. Experimental testing of complete hybrid WT drive train structure should be performed for verification of the system reliability and quality performance during in-field testing or operation. By comparing testing results of different test series – switching type of electric generator with or without presence of electric power converter, total system efficiency could be measured with operating range of drivetrain defined in detail. Operating properties such as rate of control system reaction and quality of current frequency control, acceptable range of turbine rotor speed, carrying capacity (maximal power), operating lifetime, could be verified by extensive laboratory testing under load in conditions close to exploitation.

References

- [1] BOLA AKURU, U., KAMPER, J.M.: *Contemporary wind generators*, Journal of Energy in Southern Africa, 26(3) (2015), pp.116-124.
- [2] YARAMASU, V., PARESH, C.S., KOURO, S., NARIMANI, M.: *High-power wind energy conversion systems: State-of-the-art and Emerging technologies*, Proceedings of IEEE, 103(5) (2015), pp.740-788.
- [3] AKHILESH KUMAR, G., HIMANSHU, B., PAULSON, S.: *Generator topologies with Power electronics converters for a Wind energy conversion system: A review*, JJSER, 4(6) (2013), pp. 2686-2693.
- [4] WENPING, C., YING, X., ZHENG, T.: *Wind turbine generator technologies*, Book Chapter 7, IntechOpen, (2012).
- [5] VASIN, S., OGNJANOVIĆ, M., MILOŠ, M.: *Wind turbine with continual variation of transmission ratio – Design and testing methodology*, Proceedings of Romanian Academy, 16(2) (2015), pp.184-192.
- [6] VASIN, S.: *Novel technology in hybrid drivetrain design – wind power industry example*, Proceedings of 8th International scientific conference on defensive technologies, OTEH 2018, ISBN 978-8681123-88-1, pp.591-601.

Received: 04.03.2019.

Accepted: 15.05.2019.

Dizajn hibridnih prenosnika snage – radni princip i mogućnosti primene

Novi inženjerski izazovi u oblasti proizvodnje električne energije iz obnovljivih izvora energije u sprezi sa strogim zahtevima industrije i tržišta, usmeravaju proces razvoja pogonskih sistema vetroturbin u režimu kružnog toka – jedno rešenje daje osnovu za kontradikcije koje dovode do novih rešenja sa potencijalnim inženjerskim izazovima. Sa date tačke gledišta jedna od posledica ovakvog pristupa može biti isticanje, odnosno nametanje jedne oblasti istraživanja ispred drugih. U ekstremnom slučaju, može doći do skretanja težišta procesa razvoja sa osnovnih funkcionalnih zahteva u dizajnu sistema. U ovom radu, dat je predlog nove tehnologije pogonskog sistema vetroturbin – zupčasti planetarni prenosnik promenljivog prenosnog odnosa koji omogućava direktnu sinhronizaciju sa javnom električnom mrežom, efikasnu transformaciju energije vetra u električnu energiju i veći radni opseg rotora. Osim strukture mehaničkog sistema, koncepcije elektro-elektronskog i softverskog sistema, predložena je i nova konfiguracija vetroturbin sa širokim područjem rada.

Ključne reči: dizajn, prenosnik snage, prenosni odnos, vetroturbina, hibridni sistem.