

Development and Characterization of Non-Standard Extruded Poly(vinyl chloride) Product

Jovan Radulović¹⁾

This research work focuses on the development of extrusion of non-standard PVC pipe and characterization of the obtained product. The extrusion technology and poly(vinyl chloride) polymer are described in shortest. Non-standard extruded PVC pipes were developed in three phases. Characterization of the non-standard extruded PVC pipes includes testing of non-standard properties, standard PVC pipes characteristics and additional properties. Non-standard properties include specific dimensional (non-standard outside diameter and inside diameter), hydraulical (hydraulic burst pressure in a short period of time in water-air and water-water experiments) and mechanical (external radial compressive force and internal tensile radial strength) characteristics. The standard extruded PVC pipes characteristics were, also, determined (density, visual appearance, Vicat softening temperature, dimensional longitudinal stability and resistance to external blows and to dichloro methane). Additional tested properties are resistance to severe external blows, dimensional radial stability, impact resistance and hardness. Deliberately produced damage has no negative effect on pipes' hydraulic and mechanical characteristics. Based on presented results concerning the non-standard, standard and additional properties and deliberately produced damage, it is concluded that a high quality non-standard extruded PVC is developed.

Key words: plastics, polyvinyl chloride, extrusion, pipe, mechanical characteristics.

Introduction

THIS paper has two goals: the first is development of extrusion procedure of non-standard pipe using poly(vinyl chloride) based compound and the second is characterization of extruded non-standard poly(vinyl chloride) (abbreviated: PVC) pipe.

The characterization of non-standard extruded PVC pipes includes testing of non-standard properties, standard PVC pipes characteristics and additional properties.

Non-standard extruded PVC pipe properties are specific dimensional demands, visual demands, hydraulic demands and mechanical demands.

Standard extruded PVC pipes characteristics are density, visual appearance, Vicat softening temperature, dimensional longitudinal stability and resistance to external blows and resistance to dichloro methane.

Additional tested properties are resistance to severe external blows, dimensional radial stability, impact resistance and hardness.

Experimental part

Polyvinyl chloride

Concerning synthetic polymers, PVC based compounds can be considered as the most versatile plastic materials to processing technologies [1]. PVC based compounds can be processed by extrusion, calendering, injection molding, impregnation, blow molding, casting.

Unmodified PVC is too brittle so the appropriate additives should be added, such as heat stabilizers, UV stabilizers, plasticizers, processing aids, impact modifiers, thermal

modifiers, fillers, flame retardants, biocides, blowing agents, smoke suppressors, pigments.

PVC is mostly amorphous structure and its characteristics depend on the mean molecular mass (which is, practically, expressed using K factor introduced 1930 by Fikentscher) and additives [2].

Rigid compound for PVC pipe extrusion (mixture of PVC resin and a combination of stabilizers, lubricants, pigments and modifiers) is carefully developed to provide specific properties that are application dependent.

Extrusion

Extrusion is a compression process in which a material is forced to flow through a die orifice to provide a long continuous product whose cross-sectional shape is determined by the shape of the orifice [3].

Typical plastic materials used in extrusion are poly(vinyl chloride), polyethylene, polypropylene, polybutylene, polyacetal, polyacrylic, polystyrene, acrylonitrile butadiene styrene and engineering thermoplastics (e.g. polyamide and polycarbonate) [4,5].

In shortest, during the polymer extrusion, feedstock, i.e. compound (in pellet or powder form), is a gravity fed into a hopper and further into the barrel, where it comes in contact with a screw. The rotating screw forces the plastic compound beads forward into the barrel (which is heated to the desired melt temperature of the used plastic). Components of a screw extruder are presented in Fig. 1.

At the front of the barrel, the thermoplastic material leaves the screw and travels through a wire meshes supported by stiff breaker plate, whose most important function is to convert a "rotational memory" of the molten plastic into a "longitudinal memory".

¹⁾ Military Technical Institute (VTI), Ratka Resanovića 1, 11132 Belgrade, SERBIA
Correspondence to: Jovan Radulović; e-mail: jovan.r.radulovic@gmail.com

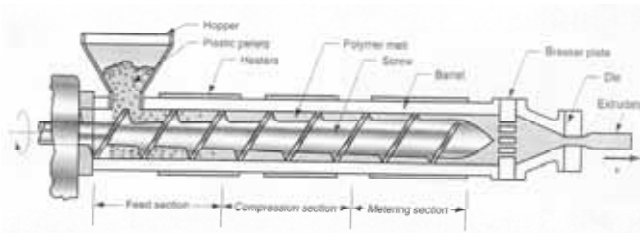

Figure 1. Components of a screw extruder

After passing through the breaker plate molten plastic enters the die, which gives the cross-sectional shape to the final product.

As it leaves the extrusion die at the exit orifice, the hot material obtains dimensions closely to a finished product dimensions and then cools into a solid state. Commonly, dimensions are established through a proper synchronization of haul-off machine (which is away from the extruder) and extruder speed [2].

The cooling of a product is usually achieved by pulling the extrudate through a sealed bath with water in liquid or chilled state.

Development of extrusion of non-standard PVC pipe

Development is, by ancestry, a French word meaning a systematic use of science and technical knowledge to meet specific objectives and requirements [6].

By the analysis of the nominal outside diameter ($d_{nom\ out}$) and corresponding tolerances for standard extruded PVC pipes determined in the SRPS EN ISO 1452-2 standard and demands for the outside diameter of nonstandard extruded PVC pipes {outside diameter (d_{out}) = $52.6^{\pm 0.2}$ mm}, it can be seen that the nearest nominal outside diameter ($d_{nom\ out}$) of a standard pipe is 50 mm and appropriate tolerances are ± 0.2 mm [7].

Development of the extrusion procedure of non-standard PVC pipe, with the outside diameter (d_{out}) = $52.6^{\pm 0.2}$ mm, inside diameter (d_{in}) = $49.6^{\pm 0.15}$ mm and wall thickness (t) cca 1.5 mm, was realized in three phases.

In the first phase of the development of the non-standard extruded PVC pipes, an attempt of obtaining the mentioned product was done on a processing equipment for the production of a nominal outside diameter ($d_{nom\ out}$) = 50 mm by adjusting certain technological parameters of extrusion.

A pipe extrusion was done using the calibrator and parts of the so called fifth zone (die and blackthorn) for the pipe nominal outside diameter ($d_{nom\ out}$) = 50 mm by raising vacuum to the highest possible level in the department where the calibrator is, and at this point of extrusion line a pipe outside diameter (d_{out}) cca 52 mm was obtained.

A haul-off machine (device which is pulling pipe through the line) is pulling pipes with the highest possible force, which causes the pipes deformation and products with the outside diameter (d_{out}) from 52.0 mm to 53.0 mm are obtained. In order to avoid mentioned pipes deformation, a pulling force of haul-off machine is reduced, but with the reduced pulling force, a continuous process was not possible because the extrusion line stopped and the extruded molten polymer hose broke. Based on the observed facts, it was concluded that it was not possible to produce a non-standard extruded PVC pipe with the required dimensions in the first phase.

In the second phase of the development of the mentioned non-standard pipe, an attempt was done using a newly produced calibrator for the pipe outside diameter (d_{out}) = 52 mm, while die and blackthorn for pipe were not changed. Sketch and external view of the calibrator for pipe outside

diameter (d_{out}) = 52 mm is presented in Figures 2 and 3.

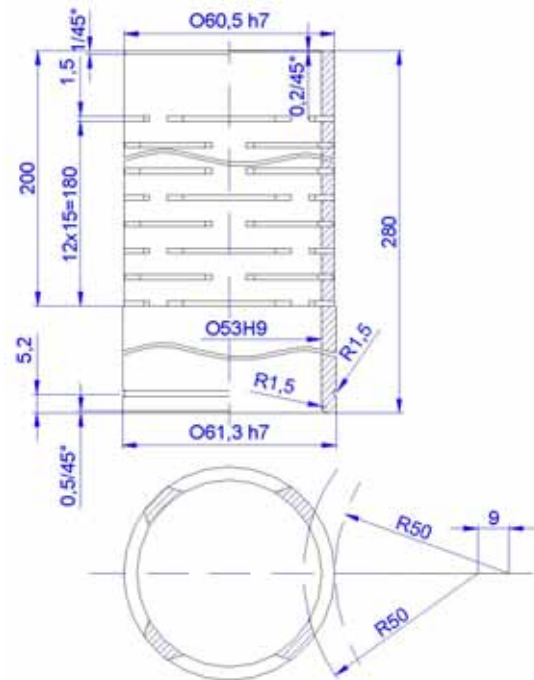

Figure 2. Sketch of the calibrator for pipe outside diameter 52 mm



Figure 3. External view of the calibrator for pipe outside diameter 52 mm

During this attempt a breaking of the extruded molten polymer hose happened. Concerning that neither in this second phase was not possible to produce a non-standard extruded PVC pipe with the required dimensions, it was concluded that it is necessary to enlarge the existing die and to produce a new blackthorn.

In the third phase an assay was done using newly produced calibrator for the pipe outside diameter (d_{out}) = 52 mm, enlarged die and newly produced blackthorn for the pipe outside diameter (d_{out}) = 52 mm and specimen of non-standard extruded PVC pipes with the required dimensions were produced, i.e. specimens had the outside diameter (d_{out}) from

52.5 mm to 52.7 mm and inside diameter (d_{in}) from 49.5 mm to 49.7 mm.

Development of the extrusion procedure of non-standard PVC pipe was done using twin screw counter rotating extruder with cooling system with vacuum bath RWN 1 produced by Cincinnati-Milacron, Wien, Austria.

Extruded material was dryblend based on OLTIVIL PVC suspension, K value 67, produced by Olchim, Ramnicu Valcea, Romania.

Investigation results of non-standard extruded PVC pipes

Characterization of non-standard extruded PVC pipes includes testing of the non-standard properties, standard PVC pipes characteristics and additional properties.

Developed extruded PVC pipes are non-standard not only for dimensional demands, but also for other technical demands, concretely:

- visual demands, i.e. that the outside and inside pipe surfaces are smooth, clean and free from scoring, cavities, tool impresses and other surface defects, and that the material does not contain any impurities visible without magnification,
- hydraulic demands, i.e. to withstand a meaningful level of internal hydraulic fluid pressure in a short period of time and
- mechanical demands, i.e. to withstand an action of a static force at the external and internal side.

Non-standard properties include specific dimensional non-standard {outside diameter (d_{out}) and inside diameter (d_{in})}, hydraulic (hydraulic burst pressure in a short period of time in water-air and water-water experiments) and mechanical (external radial compressive force and internal tensile radial strength) characteristics.

Standard extruded PVC pipes characteristics were also determined (density, visual appearance, Vicat softening temperature, dimensional longitudinal stability and resistance to the external blows and to dichloro methane).

Additional tested properties are resistance to severe external blows, dimensional radial stability (DRS), impact resistance and hardness.

Non-standard properties testing results of non-standard extruded PVC pipes

Dimensional testing results

A dimensional control, done at 30 pieces of non-standard extruded PVC pipes, pointed out that the outside diameter (d_{out}) is from 52.5 mm to 52.7 mm, inside diameter (d_{in}) is from 49.4 mm to 49.7 mm and wall thickness (t) is cca 1.5 mm.

Visual testing results

By the visual inspection of non-standard extruded PVC pipe it was found that the outside and inside pipe surfaces are smooth, clean and free from scoring, cavities, tool impresses and other surface defects, and that the material does not contain any impurities visible without magnification. Pipe specimen with the accepted visual appearance is presented in Fig.4.

Visual inspection of pipe specimen, obtained in the first phase of the development of non-standard extruded PVC pipe, is done. Impurities are observed at few specimens and visual appearance of these pipes is presented in Fig.5. All pipes obtained in this first phase are rejected, because the dimensional requirements were not fulfilled.



Figure 4. Pipe with the accepted visual appearance



Figure 5. Pipe specimen with the observed impurity

Hydraulic testing results

Determination of the hydraulic requirements of the non-standard extruded PVC pipe consists of testing of a burst pressure in a short period of time. The burst pressure is determined under the influence of internal hydraulic pressure of water, and in the first experiment the air was around a pipe (water-air) and in the second experiment the water was around a pipe (water-water).

For determination of a pipe hydraulic burst pressure in the water-air experiment, a compact tool, presented in Fig.6, is used. Pipe is mounted on two supports of this compact tool, and axial stiffening is realized by the internal central carrier.

For determination of the hydraulic burst pressure in the water-water experiment a multi-pieces tool, presented in Fig.7, is used. This tool consists of two fasteners (upper and lower) and the pipe is mounted between them, and axial stiffening is realized outside using two plates and four rods.

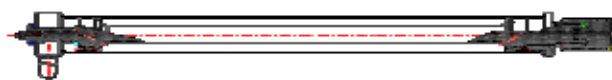

Figure 6. Compact tool for hydraulic burst pressure pipe testing



Figure 7. Multi-pieces tool for hydraulic burst pressure pipe testing

Results of determination of the hydraulic burst pressure of non-standard extruded PVC pipe with the accepted visual appearance in the water-air experiment and in the water-water experiment are presented in Table 1.

Table 1. Results of determination of the hydraulic burst pressure of non-standard extruded PVC pipe

Characteristic	Kind of experiment	
	Experiment water-air	Experiment water-water
Hydraulic burst pressure, MPa	3.5	3.4

Time of pressurizing test pipe up to bursting in the water-air experiment was 2.4 seconds and in the water-water experiment it was 17 seconds.

Pipe with the accepted visual appearance after hydraulic burst pressure testing is presented in Fig.8.

A pipe specimen with impurities (presented in Fig.5) is exposed to the action of internal hydraulic pressure, but it was not possible to examine hydraulic burst pressure of this pipe, because the pipe leaking was observed at the pressure of 0.8 MPa (Fig.9).



Figure 8. Pipe with the accepted visual appearance after hydraulic burst pressure testing



Figure 9. Pipe specimen with the observed impurities during testing under the influence of hydraulic pressure

Mechanical testing results

Investigation of the mechanical demands of the non-standard extruded PVC pipe consists of determining the resistance to external compressive stress in radial direction (so called radial compressive force) and determining the resistance of pipe, i.e. ring to internal tensile stress in radial direction (so called tensile ring force).

A pipe specimen 50 mm long (l), used for testing of the resistance to radial compressive force, is presented in Fig.10.



Figure 10. Pipe specimen before testing of the resistance to radial compressive force

Pipe specimen is stressed from the outside with a compressive stress at the speed of 1 mm/min in radial direction (Fig.11) up to the moment when the internal surfaces of the pipe touch each other (Fig.12).

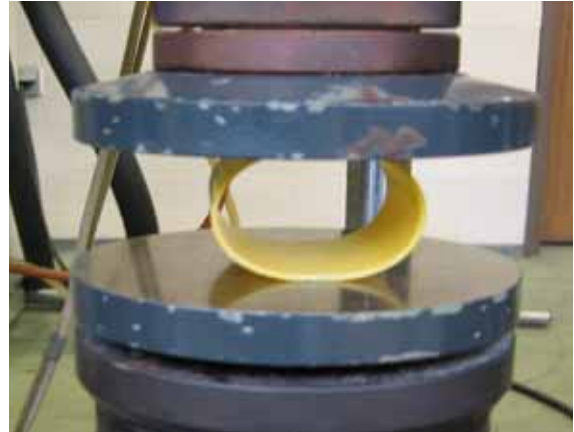

Figure 11. Pipe specimen during testing of resistance to external compressive stress in radial direction

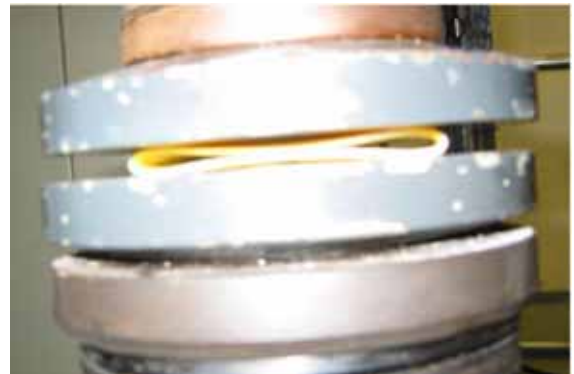

Figure 12. Pipe specimen at the moment when internal surfaces touched each other under the influence of the external compressive stress in radial direction

Fracture of the tested pipe specimen was not observed. Visual appearance of the pipe specimen after testing resistance to radial compressive force is presented in Fig.13.



Figure 13. Pipe specimen after testing of the resistance to radial compressive force

Ring shape specimen 10 mm wide (w) is used for testing of the resistance of pipe, i.e. ring to internal tensile stress in radial direction and is presented in Fig.14.

Ring shape specimen was stressed up to breaking with tensile force at the speed of 100 mm/min using a specific tool. Tool with the mounted ring shape specimen, cut from the pipe with the accepted visual appearance, is presented in Fig.15.



Figure 14. Ring shape specimen with the accepted visual appearance for tensile testing



Figure 15. Specific tool for tensile testing with mounted ring shape specimen with the accepted visual appearance

Table 2. Tensile breaking force and tensile strength of rings with the accepted visual appearance

Rsm	1	2	3	4	5	6	7	8	9	10	11	12	13	14	15	16	17	18	19	20
Tbf, (N)	1790	1780	1740	1730	1790	1780	1730	1760	1740	1750	1740	1770	1710	1750	1730	1750	1750	1730	1740	1760
Ts, (MPa)	59.66	59.33	58.00	57.66	59.66	59.33	57.66	58.66	58.00	58.33	58.00	59.00	57.00	58.33	57.66	58.33	58.33	57.66	59.00	58.66

Ring specimen mark (abbreviated: Rsm), tensile breaking force (abbreviated: Tbf) and tensile strength (abbreviated: Ts) of rings with the accepted visual appearance are presented in Table 2.

Arithmetic mean values and standard deviations of the presented 20 single values of tensile breaking force of rings, cut from the pipe with the accepted visual appearance, is (1751.0±21.9) N and tensile strength of the same rings is (58.4±0.73) MPa.

Standard properties testing results of non-standard extruded Pvc pipes

Characteristics, determined for the standard extruded PVC pipes, are tested using the non-standard extruded PVC pipes specimens.

This examination includes density, visual appearance, resistance to external blows, Vicat softening temperature, dimensional stability and resistance to dichloromethane at a specified temperature testing.

Standard extruded PVC pipes quality requirements

Standard extruded PVC pipes quality requirements, defined at the SRPS EN ISO 1452-2 standard, are presented in Table 3 [7].

Non-standard extruded PVC pipes testing results and comparison with standard extruded PVC pipes quality requirements

Density of the non-standard extruded PVC pipes is 1.42 g/cm³.

Visual appearance of the non-standard extruded PVC pipes

is presented in paragraph 3.1.2. of this paper (outside and inside pipe surfaces are smooth, clean and free from scoring, cavities, tool impress and other surface defects, and the material does not contain any impurities visible without magnification).

Table 3. Standard extruded PVC pipes quality requirements according to the SRPS EN ISO 1452-2 standard

Property	Requirements	Method
Density	from 1.350 g/cm ³ to 1.460 g/cm ³	SRPS EN ISO 1183-1, immersion method [8]
Visual appearance	outside and inside pipe surfaces should be smooth, clean and free from scoring, cavities, tool impress and other surface defects; material does not contain any impurities visible without magnification	Visual inspection
Resistance to external blows	the maximum total number of failure divided by the total number of blows is 10 %; blow should be done using striker with d25 type nose 0.5 kg mass from 1.0 m height according to paragraphs 5. and 6. of the SRPS EN ISO 744 standard; a minimum of 25 blows without failure should be obtained before test may be discontinued	SRPS EN ISO 744 [9]
Vicat softening temperature	≥ 80 °C	ISO 2507-1[10]
Dimensional stability	longitudinal reversion, maximum 5 %	SRPS EN ISO 2505 [11]
Resistance to dichloro methane	no attack at any part of the surface of the specimen at temperature (15 ±1) °C	ISO 9852 [12]

Resistance to external blows was tested on 35 specimens, 200 mm long. Three blows were done at each specimen (total 105 blows). Neither failure nor damage at any specimen after any blow was recorded.

Vicat softening temperature of the non-standard extruded PVC pipes is 88 °C.

Dimensional stability in the SRPS EN ISO 2505 standard is defined only by the expression [11]:

$$DSL = (\text{Initial length} - \text{Length after warming}) / \text{Initial length}$$

This is a dimensional stability in longitudinal direction (DSL).

Dimensional stability of the non-standard extruded PVC pipes in longitudinal direction is 4 %.

Dimensional stability of the non-standard extruded PVC pipes specimen in longitudinal direction, obtained in the first phase of the development of extrusion process of the mentioned pipes, is 7 %. This unacceptable result (highest accepted dimensional stability in longitudinal direction is 5 %) is a consequence of the highest possible extension in the longitudinal direction, caused by the applied highest possible vacuum in the zone with calibrer.

Resistance to dichloro methane of the non-standard extruded PVC pipes was done at 16 °C and no attack at any part of the surface of the specimen was observed.

Additional properties testing results of non-standard extruded PVC pipes

Besides the examination of the characteristics which are determined for the standard extruded PVC pipes, an additional testing of non-standard extruded PVC pipes was done. This additional testing includes examination of the following properties:

- resistance to much more severe external blows using heavier falling weight from higher height,
- dimensional stability in radial direction,
- impact resistance according to the SRPS EN ISO 179-1 standard [13] and
- hardness according to the SRPS EN ISO 868 standard [14].

A certain number of the non-standard extruded PVC pipes were exposed to a hit of striker with nose type d25 of a heavier falling weight (1.6 kg instead of 0.5 kg according to SRPS EN ISO 744) from a higher height (2.5 m instead 1.0 m according to SRPS EN ISO 744).

Neither failure nor damage at any tested specimen after any blow was recorded. On an external surface of these specimens, only a round impress of 8 mm diameter is observed.

This activity imitates a possible, unwanted situation, i.e. that pipe can be hit by a noncareful handling during a completion of the assembly, whose part is also a non-standard extruded PVC pipe. Surface of a round impress is almost at the same plane as the outside surface of pipes around the impress.

Specimen for hydraulic burst pressure testing 410 mm long, containing a round impress, and specimen for tensile breaking force testing 10 mm wide, also containing a round impress, are cut from the non-standard extruded PVC pipes.

Hydraulic burst pressure of the non-standard extruded PVC pipes specimen, which contains a round impress, was tested using a compact tool (presented in Fig.6) in the water-air experiment. Hydraulic burst pressure of the specimen with a round impress is 3.4 MPa and time up to bursting is 2.5.

Ring from non-standard extruded PVC pipes, which contains a round impress, is presented in Fig.16. These rings are tested in the same way as rings cut from the non-standard extruded PVC pipes without a round impress. Ring with a

round impress, mounted on a specific tool for tensile testing, is presented in Fig.17.

Ring specimen mark, tensile breaking force and tensile strenght of the ring with a round impress are presented in Table 4.



Figure 16. Ring with a round impress



Figure 16. Ring with a round impress, mounted on a specific tool for tensile testing

Table 4. Tensile breaking force and tensile strength of the ring with a round impress

Ring specimen mark	1	2	3	4	5	6	7
Tensile breaking force, (N)	1680	1720	1690	1670	1680	1700	1680
Tensile strength, (MPa)	56.0	57.33	56.33	55.66	56.0	56.66	56.0

Arithmetic mean values and standard deviations of the presented 7 single values for tensile breaking force for specimen with a round impress is $(1.688.6 \pm 16.7)$ N, and for tensile strength for same specimen is (56.3 ± 0.56) MPa.

Although it is not stated in the SRPS EN ISO 2505 standard, a dimensional stability of the non-standard extruded PVC pipes specimen in radial direction (DSR) was determined according to the expression:

$$DSR = (\text{Initial girth} - \text{Girth after warming}) / \text{Initial girth}.$$

Dimensional stability of the non-standard extruded PVC pipes specimen in radial direction is 0.38 %.

Impact resistance examination of the specimen (dimensions 50 mm x 6 mm x wall thickness), cut from the non-standard extruded PVC pipes, was done. None of the tested specimen was broken.

Hardness of the external surface of specimen, (dimensions 40 mm x 20 mm x wall thickness), cut from the non-standard extruded PVC pipes, is 82 H Sh D.

Testing results analysis

By comparing dimensional requirements (2.3. paragraph of this paper) and dimensional testing results (3.1.1. paragraph of this paper) it can be seen that the non-standard extruded PVC pipes fulfill the mentioned requirements.

By comparing visual requirements (3. paragraph of this paper) and visual testing results (3.1.2. paragraph of this paper) it can be seen that the non-standard extruded PVC pipes fulfill the visual requirements.

By comparing hydraulic requirements (3. paragraph of this paper) and hydraulic testing results (3.1.3. paragraph of this paper) it can be seen that the non-standard extruded PVC pipes withstand a meaningful, even high, level of internal hydraulic pressure of fluid in a short period of time. Hydraulic burst pressure of these PVC pipes, caused by the influence of internal hydraulic pressure, in the water-air experiment was 3.5 MPa, in the water-water experiment was 3.4 MPa and pressurizing times up to bursting were 2.4 seconds and 17 seconds, respectively.

By comparing mechanical requirements (3. paragraph of this paper) and mechanical testing results (3.1.4. paragraph of this paper) it can be seen that the non-standard extruded PVC pipes withstand a meaningful action of the static force at the external and internal side.

These pipes have a high resistance to the external compressive stress in radial direction because the internal pipe surfaces touch one another under the action of mentioned force without failure.

These specimens withstand meaningful internal tensile stress in radial direction because the obtained tensile ring force and tensile strength are high.

By comparing the standard extruded PVC pipe quality requirements (3.2.1. paragraph of this paper) and testing results of non-standard extruded PVC pipes (3.2.2. paragraph of this paper), it is obvious that the non-standard extruded PVC pipes fulfill all quality requirements for density, visual appearance, resistance to external blows, Vicat softening temperature, dimensional stability and resistance to dichloro methane at the specified temperature.

By comparing hydraulic burst pressure testing results of the non-standard extruded PVC pipe with the accepted visual appearance, presented in 3.1.3. paragraph of this paper (3.5 MPa and pressurizing time up to bursting 2.4 seconds) and additional test results of the non-standard extruded PVC pipe, concretely hydraulic burst pressure testing results of the specimen with a round impress, presented in 3.3. paragraph of this paper (3.4 MPa and pressurizing time up to bursting 2.5 seconds), it can be seen that there are no differences in the obtained results.

By comparing tensile breaking force and tensile strength test results of the non-standard extruded PVC pipe ring with the accepted visual appearance, presented in 3.1.4. paragraph of this paper (1751 N and 58.4 MPa, respectively) and additional test results of the non-standard extruded PVC pipe, concretely hydraulic burst pressure test results of the specimen with a round impress, presented in 3.3. paragraph of this paper (1689 N and 56.3 MPa, respectively), very small differences are established (0.35 %).

These data pointed out that a deliberately produced damage, i.e. round impress, caused by a blow with striker 1.6 kg mass from height 2.5 m, has no influence on the non-standard extruded PVC pipe quality.

Dimensional stability in radial direction, impact resistance and hardness of the non-standard extruded PVC pipes specimen indicated to the accepted quality of the tested product.

Conclusions

1. Extrusion procedure of the non-standard pipes using poly(vinyl chloride) based compound is developed.
2. Characterization of the non-standard extruded poly(vinyl chloride) pipes is done, i.e. non-standard, standard and additional characteristics of this product are examined. Non-standard and standard extruded PVC pipes characteristics are tested using the non-standard extruded PVC pipes and additional performance are tested using the specimen cut from the mentioned pipes.
3. Developed non-standard extruded PVC pipes fulfill the requirements for the non-standard properties (dimensional, hydraulic and mechanical requirements). It is important to point out that the hydraulic burst pressure of the tested specimen is 3.5 MPa (in the water-air experiment) and 3.4 MPa (in the water-water experiment) and neither failure nor serious damage happened when the internal surfaces of the PVC non-standard pipes touch one another under the action of a radial compressive force.
4. Developed non-standard extruded PVC pipes fulfill the requirements for all tested characteristics of the standard extruded PVC pipes (density, visual appearance, resistance to external blows, Vicat softening temperature, dimensional stability and resistance to dichloro methane at the specified temperature).
5. Besides the non-standard and standard extruded PVC pipes characteristics, additional properties are determined:
 - resistance to external blows using same striker type nose with the heavier falling weight (1.6 kg instead of 0.5 kg) from the higher height (2.5 m instead 1.0 m),
 - dimensional stability in radial direction,
 - impact resistance and
 - hardness.
6. Possible, unwanted situation in which non-standard extruded PVC pipe can be hit by a noncareful handling

during the assembling of the mentioned pipe is imitated. Based on the pipe hydraulic burst pressure testing and ring tensile properties testing, it was concluded that deliberately produced damage (hit of falling weight 1.6 kg mass from 2.5 m height) has no negative effect on the pipes characteristics.

7. All presented data pointed out to a high quality of the developed non-standard extruded PVC pipes.

Literature

- [1] BRYDSON, A.: *Plastics Materials*, Newness-Butterworths, London, 1975.
- [2] HÜLSMANN,., NOWACK, E.: *70 years of experience with PVC pipes*, www.teppfa.com www.teppfa.com, 21.03.2011.
- [3] OBERG,., JONES, D., HORTON, L., RYFFEL, H.: *Machinery's Handbook (26th ed.)*, Industrial Press, New York, 2000 ISBN 0-8311-2635-3.
- [4] KELLY,., MILEIKO, T.: *Fabrication of Composites*, Elsevier Science Publishers B.V., Amsterdam, 1983
- [5] RADULOVIĆ, J., JOVANČIĆ, S., DŽELEBDŽIĆ, N.: *Injection Moulded Polycarbonate Covers of Rocket Launcher Tubes*, Scientific Technical Review, ISSN 1820-0206, 2014, Vol.64, No.1, pp. 55-61
- [6] www.dictionary.com/browse/development
- [7] SRPS EN ISO 1452-2 Plastics piping systems for water supply and for buried and above-ground drainage and sewerage under pressure - Unplasticized poly (vinyl chloride) (PVC-U) - Part 2: Pipes, Institute for Standardization of Serbia, Belgrade, 2011.
- [8] SRPS EN ISO 1183-1 Plastics-Methods for determining the density of non-cellular plastics-Part 1: Immersion method, liquid pycnometer method and titration method, Institute for Standardization of Serbia, Belgrade, 2013.
- [9] SRPS EN ISO 744, Plastics piping and ducting systems - Thermoplastics pipes - Test method for resistance to external blows by the round-the-clock method, Institute for Standardization of Serbia, Belgrade, 2008.
- [10] ISO 2507-1, Thermoplastics pipes and fittings - Vicat softening temperature - Part 1: General test method, ISO (the International Organization for Standardization), Case postale 56, CH-1211 Geneva 20, Switzerland, 2011.
- [11] ISO 2505, Thermoplastics pipes - Longitudinal reversion - Test method and parameters, ISO, Case postale 56, CH-1211 Geneva 20, Switzerland, 2013.
- [12] ISO 9852, Unplasticized poly (vinyl chloride) (PVC-U) pipes - Dichloromethane resistance at specified temperature (DCMT) - Test method, ISO, Case postale 56, CH-1211 Geneva 20, Switzerland, 2012
- [13] SRPS EN ISO 179-1, Plastics-Determination of Charpy impact properties - Part 1- Non-instrumented impact test, Institute for Standardization of Serbia, Belgrade, 2011.
- [14] SRPS EN ISO 868, Plastics and ebonite - Determination of indentation hardness by means of a durometer (Shore hardness), Institute for Standardization of Serbia, Belgrade, 2015.

Received: 15.10.2015.
Accepted: 28.12.2015.

Razvoj i karakterizacija nestandardnog ekstrudiranog poli(vinil hlorldnog) proizvoda

U ovom istraživačkom radu pažnja je posvećena razvoju postupka ekstrudiranja nestandardne PVC cevi i karakterizaciji dobijenog proizvoda. Tehnologija ekstrudiranja i polimer poli(vinil hlorld) ukratko su opisani. Razvoj nestandardnih ekstrudiranih PVC cevi je realizovan u tri faze. Karakterizacija nestandardnih ekstrudiranih PVC cevi je obuhvatila ispitivanje nestandardnih osobina, karakteristike standardnih ekstrudiranih PVC cevi i dodatne osobine. Nestandardne osobine su obuhvatile specifične dimenzionalne (nestandardni spoljni i unutrašnji prečnik), hidrauličke (hidraulički pritisak prskanja u kratkom vremenskom periodu u eksperimentima voda-vazduh i voda-voda) i mehaničke karakteristike (spoljna pritisna radijalna sila i unutrašnja zatezna radijalna sila). Karakteristike standardnih ekstrudiranih PVC cevi su, takođe, ispitane (gustina, vizuelni izgled, temperatura omekšavanja po Vikatu, uzdužna dimenzionalna stabilnost i otpornost prema spoljnom udaru i prema dejstvu metilen hlorlda). Dodatne osobine su otpornost prema oštrijem spoljnom udaru, radijalna dimenzionalna stabilnost, udarna žilavost i tvrdoća. Namerno izazvano oštećenje nema negativan uticaj na hidrauličke i mehaničke karakteristike cevi.

Na osnovu prikazanih rezultata za nestandardne, standardne i dodatne osobine i namerno izazvano oštećenje, zaključeno je da su razvijene visokokvalitetne nestandardne ekstrudirane PVC cevi.

Ključne reči: plastični materijali, polivinilhlorld, ekstruzija, cev, mehaničke karakteristike.

Развитие и характеристики нестандартного экструдированного поли (винилхлорида) продукта

В этом исследовании внимание было уделено развитию процесса экструзии нестандартных труб из ПВХ и характеристикам полученного продукта. Технология экструдирования и полимер поли(винилхлорида) вкратце описаны. Разработка нестандартных экструдированных труб из ПВХ была реализована в три этапа. Характеристики нестандартных экструдированных ПВХ труб покрыты тестирование нестандартных функций, характеристики стандартных труб из экструдированного ПВХ и дополнительные функции. В нестандартные функции включены срецифические габаритные (нестандартный внешний и внутренний диаметры), гидравлические (гидравлическое давление распыления в течение короткого периода времени в экспериментах воздух-вода и вода-вода) и механические характеристики (внешняя радиальная сжимающая сила и внутренняя растяжная радиальная силы). Характеристики стандартных экструдированных труб из ПВХ были также исследованы (плотность, внешний вид, температура смягчения согласно Викату, продольная габаритная стабильность и устойчивость к внешним воздействиям и к действию хлористого метилена). Дополнительные возможности и свойства - устойчивость к резким внешним ударам, радиальная габаритная стабильность, ударная прочность и твердость. Преднамеренно

причинённое повреждение не вызвало никакого отрицательного влияния на гидравлические и механические свойства трубы.

На основании показанных результатов для нестандартных, стандартных и дополнительных функций и свойств и преднамеренно причинённого ущерба, был сделан вывод, что разработаны высококачественные нестандартные экструдированные ПВХ трубы.

Ключевые слова: пластмассы, поливинилхлорид, экструзия, труба, механические свойства.

Développement et caractérisation d'un produit de poly(vinylchloride) extrudé et non standardisé

Dans ce travail de recherche l'attention est prêtée au développement du procédé d'extrusion du tuyau PVC non standardisé et à la caractérisation du produit obtenu. On a décrit brièvement la technologie d'extrusion et polymère poly(vinylchloride). Le développement des tuyaux PVC non standardisés a été réalisé à trois phases. La caractérisation de ces tuyaux PVC a compris l'examen des propriétés non standardisées, les caractéristiques des tuyaux PVC standardisés et les propriétés additionnelles. Les propriétés non standardisées ont englobé les caractéristiques spécifiques de dimension (diamètre extérieur et intérieur non standardisés, les propriétés hydrauliques (pression hydraulique d'éclatement dans la courte période temporelle pendant les tests eau – air et eau – eau) et les caractéristiques mécaniques (force radiale extérieure de pression et force radiale intérieure de résistance). On a examiné aussi les caractéristiques des tuyaux PVC standardisés et extrudés (densité, aspect visuel, température d'adoucissement selon Vicat, stabilité longitudinale de dimension et la résistance à l'impact extérieur et à l'effet de méthylène chlorure. Les propriétés additionnelles sont : résistance à l'impact fort extérieur, stabilité radiale dimensionnelle, résistance à l'impact et dureté. L'endommagement causé exprès n'a pas d'effet négatif sur les caractéristiques hydraulique et mécaniques des tuyaux. A la base des résultats présentés pour les tuyaux non standardisés, standardisés et propriétés additionnelles ainsi que les endommagement provoqués exprès on a pu conclure que les tuyaux PVC extrudés de très haute qualité ont été développés.

Mots clés: matériaux plastiques, polyvinylchloride, extrusion, tuyau, caractéristiques mécaniques.